

## SENSORLINK™ INSTALLATION MANUAL

The SensorLink Transmitter (#7610) and SensorLink Receiver (#7611) are designed to work with Davis Instruments' Weather Monitor II® and the Weather Wizard III® to enable wireless transmission of data between the sensors and console up to 400 feet (120 m). The SensorLink Transmitter/Receiver pair takes the place of the junction box and cable that would normally connect the outdoor sensors to the display console. The outdoor sensors connect to the transmitter while the display console connects to the receiver.

One transmitter can send data to any number of Monitor II or Wizard III consoles, providing the console contains an receiver. The transmitter/receiver communicate on one of 8 different ID codes set by the user. This allows multiple systems to coexist in the same geographical area.

**Note:** SensorLink operates on a low power frequency that does not require an FCC license.

### COMPONENTS

The SensorLink package includes the following. Please make sure you have everything you need before beginning.

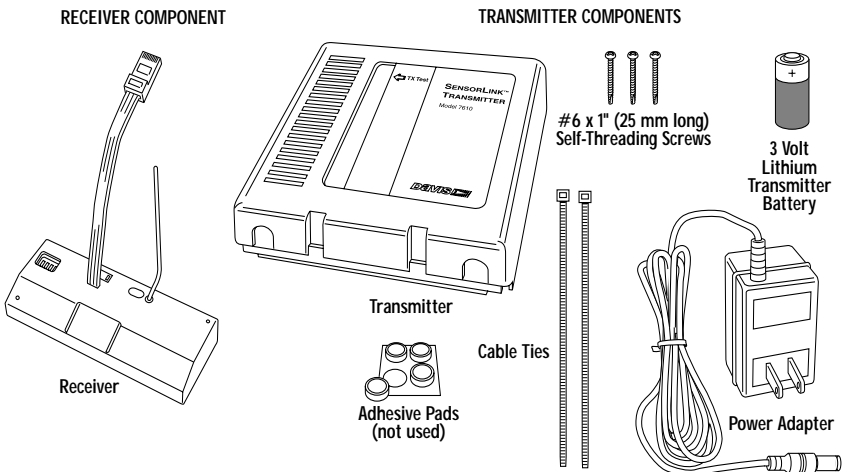

---

## TOOLS AND MATERIALS NEEDED

In addition to the components listed above, you may need some of the following tools and materials. Please be sure you have everything you need before beginning the installation.

- ◆ Phillips Screwdriver
- ◆ Pencil or Other Pointed Object

## CONFIGURING TRANSMITTER/RECEIVER PAIR

Both the transmitter and receiver have a set of dip switches which enable you to change the ID code and warnings settings.

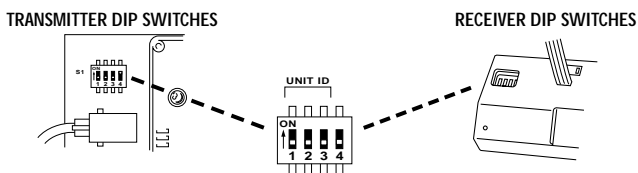

### Setting the ID Code

The wireless weather station may be set to use any of eight selectable ID codes (the default is ID Code #1). The transmitter and receiver will only communicate with each other if they are both set to the same ID code. Use the default setting unless you have another Davis wireless weather station operating nearby which you want to work separately from the new system. The dip switch settings for the eight possible codes are shown below.

ID CODE	DIP SWITCH 1	DIP SWITCH 2	DIP SWITCH 3
#1 (default)	off	off	off
#2	off	off	ON
#3	off	ON	off
#4	off	ON	ON
#5	ON	off	off
#6	ON	off	ON
#7	ON	ON	off
#8	ON	ON	ON

To change to another ID, toggle dip switches 1, 2, and/or 3 on both the transmitter and receiver to the desired code. Remember that the transmitter and receiver must use the same ID code in order to communicate. If, later, you ever want to change ID codes, remember that you will need to remove and reapply power to the console before the changes take effect.

---

**Note:** Dip switch #4 is used for testing and warnings, not for ID codes.

---

---

## Silent Operating Mode

Dip switch #4 on the receiver allows you to set the console to either stay silent or emit audible warnings. In *Silent Mode*, the console does not beep to indicate problems such as low battery or poor reception. The factory sets Silent Mode off as the default so that the console will warn you when problems occur. When Silent Mode is OFF:

- ◆ **Triple Beep Warns of Transmitter Battery Problem**  
A triple beep every 10 minutes indicates that the transmitter battery is extremely low on power. If you hear a triple beep, replace the transmitter battery as soon as possible to prevent possible loss of data.
- ◆ **Double Beep Warns of Data Reception Problem**  
A double beep indicates that the SensorLink has not received data for at least 30 minutes.

Dip switch #4 on the console's receiver controls Silent Mode (see figure below).

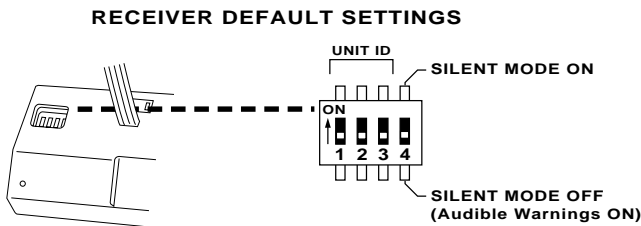

You can set your console to Silent Mode on or off. If you were to power up your console with dip switch #4 in the “OFF” position (as shown above), Silent Mode would be off and audible warnings would be on. On the other hand, if you were to power up your console with the dip switch in the “ON” position (not shown), Silent Mode would be on and audible warnings off.

The key is the position of dip switch #4 when you power up the console. Flipping the dip switch *without* repowering up the console will take you in and out of Test Mode (see below for details), but will not change the Silent Mode setting.

## Test Mode

To test signal reception at any point, simply flip the receiver's dip switch #4 to the opposite position from where it was when the console powered up. (You will hear a periodic beep about every 2.5 seconds if the transmitter is within range of the receiver and is also set to Test Mode.)

Therefore, to set the console's operating mode (Silent Mode on or off), flip dip switch #4 to the appropriate side and then repower the console. Then, to place the receiver in Test Mode, simply flip the dip switch to the opposite side.

---

## INSTALLATION

The instructions below will take you through the process required to install the transmitter and receiver.

### Choosing a Location for Transmitter and Receiver

The range of the radio transmission depends on several factors. Try to position the transmitter and the receiver as close as possible for best results.

Typical maximum ranges:

- ◆ Line of Sight: 400 feet (120 m)
- ◆ Through Walls and Ceilings: 100 to 200 feet (30 to 60 m)
- ◆ Through Trees and Foliage: 100 to 200 feet (30 to 60 m)

As you position your console, be aware of possible interference from cordless phones and other items. To prevent interference, maintain a distance of 10 feet between the console and the cordless phone (handset and base). Also, for best reception, avoid positioning the console near large metallic surfaces (e.g., most refrigerator surfaces).

### Installing Transmitter and Receiver

Install the transmitter in an attic or garage, or in one of Davis's weatherproof shelters.

#### 1. Remove the cables from your existing junction box.

We recommend that you label the end of each cable as you disconnect it. This will help you identify the cables when attaching them to the transmitter.

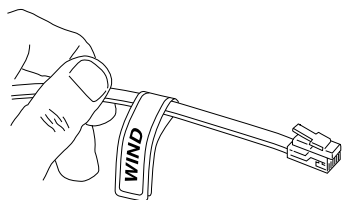

2. Remove the cover from the transmitter by pushing down on the tabs at the top until you can remove the tabs from the slots.

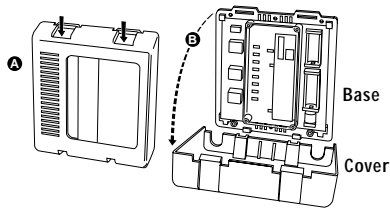

3. Attach the base to the mounting surface using the #6 x 1" screws. Use two screws (as pictured below) when attaching to a stud. Use three screws (as pictured below) in any other case.

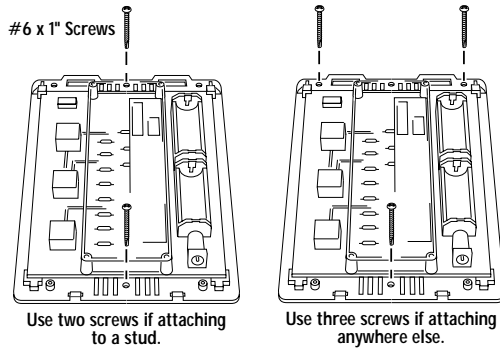

4. Insert the sensor cables in the appropriate jacks, as shown below.

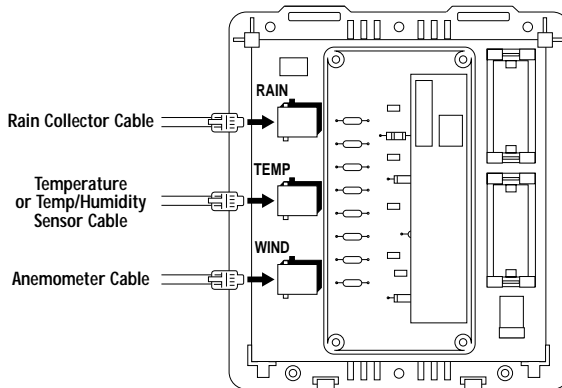

- Gather the sensor cables and secure them to the cable tie lug using a cable tie. When tightening the cable tie, make sure the cables are on top of the lug.

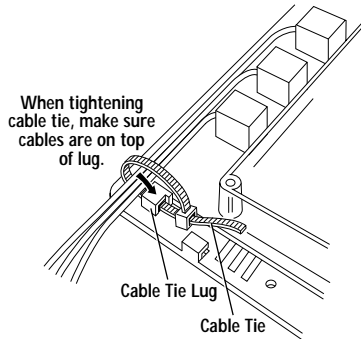

- Apply power to the transmitter using one of the options indicated below. If you have a solar-powered system, connect the gel cell battery. If you have a non-solar-powered system, decide whether you want to install the power adapter OR the lithium battery (the two will NOT work in tandem or as backup). Davis recommends the battery to ensure power during storms. If used as the primary power source, one fresh lithium battery should provide about six months of service. Use two fresh lithium batteries to double life (second is not provided).

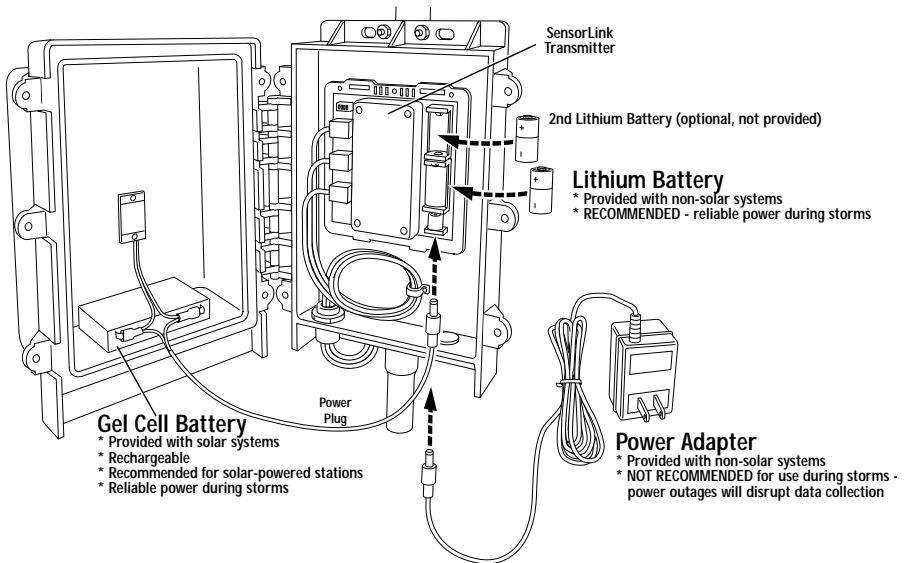

**Note:** This illustration (as well as the following one) shows the transmitter mounted inside a Davis Multi-Purpose Shelter (#7728). The Multi-Purpose Shelter is not required, but the transmitter does need to be mounted in weatherproof location.

7. Test the transmitter by setting dip switch #4 to the "Test" position, as shown below. You should see a flashing LED indicating that the sensor unit is transmitting.

#### TRANSMITTER TEST

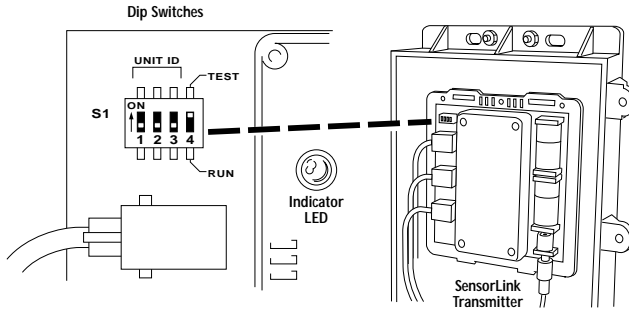

8. Install the receiver into the console base and apply power as shown below. Be sure to connect the receiver's cable plug into the jack marked "Junction Box" on the underside of the station console.

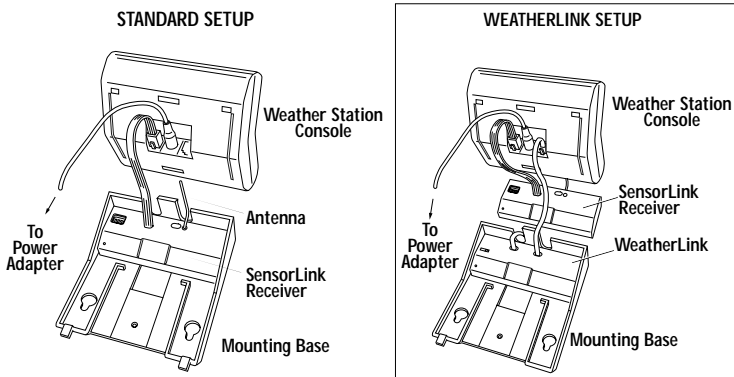

When you apply power to the console, the console should beep three times within 20 seconds to indicate that the console and receiver are working properly (or 4 times within 30 seconds, with the optional WeatherLink).

---

## Testing Reception

1. Move dip switch #4 on the receiver to the position opposite its starting position.  
The setting for Test Mode is always the opposite of wherever the dip switch was set when power is applied to the console.

In Test Mode, the console will beep whenever it receives data from the transmitter (approximately every 2.5 seconds). If the two units are in range you should hear a beep about every 2.5 seconds. If not, try moving the console closer to the transmitter.

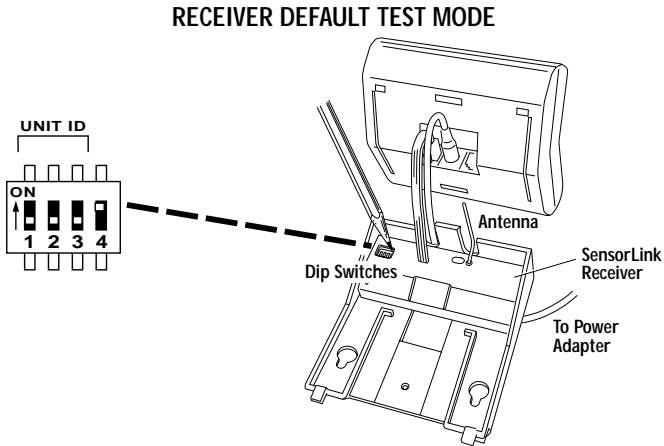

2. Check all of the readings on your display to be sure they appear normally (i.e., not "dashed out").  
Consult your station manual for instructions on displaying the various readings. Spin the wind cups and move the wind vane to verify wind speed/direction readings. Note that some readings must be calibrated in order to read correctly; calibration instructions are contained in the station manual.

If problems occur reading the outdoor sensors, consult the troubleshooting guide at the end of this manual. If the inside temperature, inside humidity, or barometer are not working properly, consult the station manual for troubleshooting.

3. Once finished testing, return dip switch #4 on the transmitter and receiver to their original settings.  
This will deactivate Test Mode; the LED Indicator on the transmitter should stop flashing. On the receiver, position dip switch #4 to Silent Mode on or off, as desired, and remove and reapply power to the console.

---

**Note:** Leaving the transmitter in Test Mode will cause the LED indicator to flash unnecessarily and thus drain additional and nonessential power from your power supply.

---

4. Reattach the transmitter cover to the base.

Make sure the tabs on top of the cover snap back into their slots, locking the cover in place.

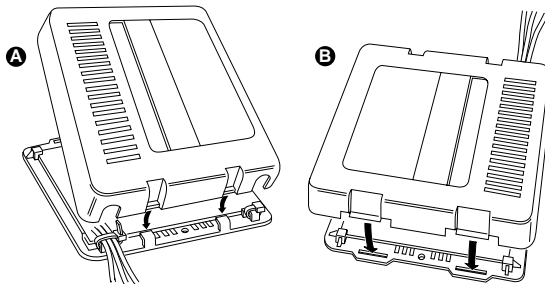

5. Reattach the console base.

The closed console, with and without optional WeatherLink, is displayed below.

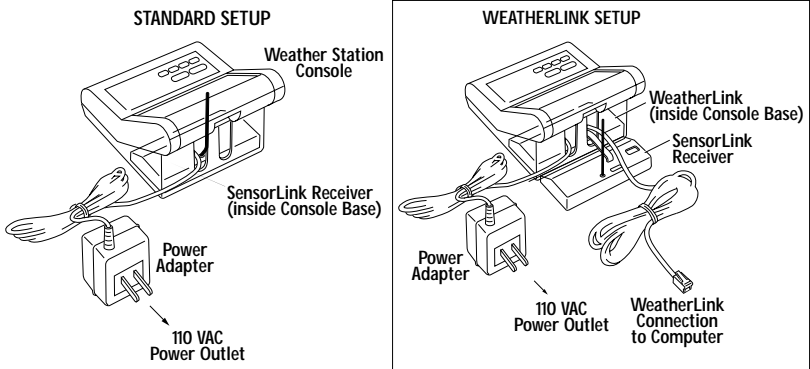

---

## TROUBLESHOOTING

While the Wireless Weather Station is designed to provide years of trouble-free operation, occasional problems may arise. If you experience a problem, please check the troubleshooters listed below before calling the factory. If you still are unable to solve the problem, call the factory at (510) 732-7814 for assistance. Please do not return your unit for repair without prior authorization.

◆ **Console is receiving erratic data**

Enable the Test Mode on the transmitter. If two beeps or more are heard in a 2.5-second interval, then another Davis wireless system may be operating nearby on the same ID, or a cordless phone may be operating within 10 feet of the receiver. Either try changing to a different ID code on both the receiver and the transmitter, or try moving the phone. Reapply power to the console to activate the new ID code.

◆ **Console is not receiving any data**

The transmitter and the receiver may be too far apart, or something in their path may be interfering, such as foliage, furnishings or cordless phones. Enable Test Mode on the transmitter to see if it is receiving data. Try moving the receiver closer to the transmitter or vice versa; or eliminating possible path interferences.

◆ **Console is emitting beeps**

If you hear *single beeps*, flip dip switch #4 to turn off Test Mode in both the transmitter and receiver.

If you hear a *double beep*, the SensorLink Receiver in the console is not receiving data. This occurs when the receiver has not received data for 30 minutes. Try moving the receiver closer to the transmitter or vice versa; or eliminating possible path interferences.

If you hear a *triple beep*, the transmitter is extremely low on power—replace battery immediately.

◆ **Data from the optional WeatherLink program shows temperature, humidity, or wind values that were constant over some period**

The SensorLink Receiver in the console did not receive new data during this period and passed the last good data to the WeatherLink. Try moving the receiver closer to the transmitter or vice versa; or eliminating possible path interferences.

◆ **Battery(ies) are not lasting the expected 6 months (for 1 battery) or 1 year (for 2 batteries)**

Make sure dip switch #4 in the transmitter is set to OFF to prevent the LED from flashing unnecessarily when not testing. If you are using two batteries, also make sure that both are fresh when installed.

---

## SPECIFICATIONS

### SensorLink Receiver

Receive frequency: 916.5 MHz

ID codes: 8 user-selectable

Temperature range: 0 to 60 °C

### Update interval

Wind speed: 2.5 seconds

Wind Direction: 2.5 seconds

Outside Temperature: 16 seconds

Outside Humidity: 1 minute

Rain: 10 seconds (rain counts are saved in the transmitter until successfully received by the console)

### SensorLink Transmitter

Transmit frequency: 916.5 MHz

ID codes: 8 user-selectable

License: Low power (less than 1 mW), no license required

Sensor connections: Telephone modular for Anemometer, Temp/Hum Sensor, and Rain Collector

Temperature range: -40 to 60 °C

### Power Input Options

Battery power: CR-123 3- volt lithium or equal; one or two cells

AC power adapter: Davis adapter or equal (5 to 10 VDC output @ 1mA)

Solar Power Kit: Davis solar charger (Optional, product #7709. Offers the added capability of replacing current power with a rechargeable solar power supply.)

---

## FCC PART 15 CLASS B REGISTRATION WARNING

This equipment has been tested and found to comply with the limits for a class B digital device, pursuant to Part 15 of the FCC Rules. These limits are designed to provide reasonable protection against harmful interference in a residential installation. This equipment generates, uses and can radiate radio frequency energy and, if not installed and used in accordance with the instructions, may cause harmful interference to radio communications. However, there is no guarantee that interference will not occur in a particular installation.

If this equipment does cause harmful interference to radio or television reception, which can be determined by turning the equipment off and on, the user is encouraged to try to correct the interference by one or more of the following measures:

- ◆ Reorient or relocate the receiving antenna.
- ◆ Increase the separation between the equipment and receiver.
- ◆ Connect the equipment into an outlet on a circuit different from that to which the receiver is connected.
- ◆ Consult the dealer or an experienced radio/TV technician for help.

Shielded cables and I/O cords must be used for this equipment to comply with the relevant FCC regulations. Changes or modifications not expressly approved in writing by Davis Instruments may void the user's authority to operate this equipment.

---

Product Numbers: 7610 & 7611

Davis Instruments Part Number: 7395-301  
SensorLink™ Installation Manual  
Rev. E Manual (10/15/99)  
Controlled Online: Weather Manuals:Accessories:SensorLink

This product complies with the essential protection requirements of the EC EMC Directive 89/336/EC. Weather Monitor II, Weather Wizard III, and WeatherLink are registered trademarks of Davis Instruments Corp. © Davis Instruments Corp. 1998. All rights reserved.

**Davis**   
**Davis Instruments**

3465 Diablo Avenue, Hayward, CA 94545-2778

510-732-9229 • Fax: 510-732-9118

E-mail: [info@davisnet.com](mailto:info@davisnet.com) • [www.davisnet.com](http://www.davisnet.com)