

EZ-SOLAR POWER KIT

FOR EZ-MOUNT WEATHER STATIONS

This manual describes how to install and use the EZ-Solar Power Kit. The power kit enables EZ-Mount weather stations to be stand-alone units that combine sensors and console into one “EZ” package, thereby eliminating the need to run a cable to a power outlet. Most people mount the console outdoors in the station field case.

CAUTION: Please note that while we have made every attempt to design and manufacture a safe product, Davis Instruments cannot assume liability for any injury or damage caused directly or indirectly by the installation or use of this product.

COMPONENTS

The EZ-Solar Power Kit includes the following components. Please be sure you have all listed components before beginning.

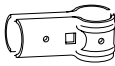

5/16"
Hex Nut



Brace Clamp

Cap

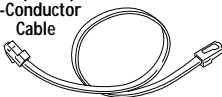

5/16" x 2"
Carriage Bolt

18" (46 cm)
8-Conductor
Cable

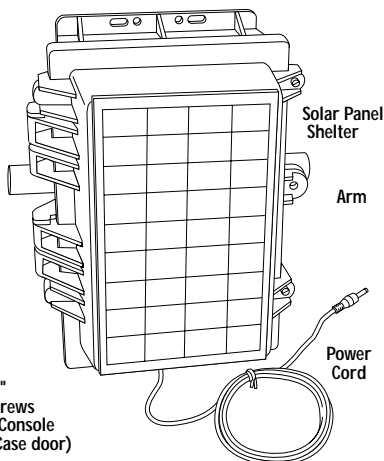

Cable Ties

#6 x 1/4"
Pan Head Screws
(for mounting Console
on Station Field Case door)



TOOLS AND MATERIALS NEEDED

You may need the following for this installation:

- ◆ Adjustable Wrench or 5/16" Wrench
- ◆ Flat Head Screwdriver
- ◆ Phillips Screwdriver
- ◆ Wire Cutters or Scissors
- ◆ Protractor (optional)
To adjust solar panel to the correct tilt angle.
- ◆ Magnetic Compass, Local Area Map, or Watch
To align solar panel to the south in the Northern Hemisphere (or north in the Southern Hemisphere). The watch may be used to set the panel facing the sun at solar noon.

LOCATION TIPS

The following tips should help you find the best possible location and position for your EZ-Solar Power Kit. If necessary, you may have to reposition your station to permit the solar panel sufficient access to the sun's rays.

- ◆ The solar panel works best when the surface of the panel receives full sunlight. Mount the panel away from fences, buildings, trees or other obstructions that may cast shadows over the panel.
- ◆ The panel should be mounted facing south in the Northern Hemisphere and north in the Southern Hemisphere for maximum sun exposure.

MOUNTING THE POWER KIT

Most people mount the power kit on the extension tube or optional tripod of their EZ-Mount weather stations. Since this manual assumes no optional accessories, a wooden post installation is described below. For tripod installation, refer to the tripod installation picture on page 3 and to your tripod manual (if necessary).

Mounting on a Wooden Post or Fence

1. Mount the EZ-Mount sensor array, if not already mounted.
Refer to the EZ-Mount weather station installation manual for instructions. If you are mounting the station on a fence, make sure the extension tube is on the side of the fence that receives the most sun (i.e., the southern side in the Northern Hemisphere or the northern side in the Southern Hemisphere).
2. Loosen the screws and saddles that hold the extension tube to the post.
Loosen the screws enough to allow the extension tube to sit about 1/16" away from the wall so that the brace clamp (for the solar power kit arm) has room to clasp around the tube.

3. Identify where you want to position the solar power kit before you install it in step 4. For additional structural support, rest the arm on the lower extension tube saddle or tripod collar.

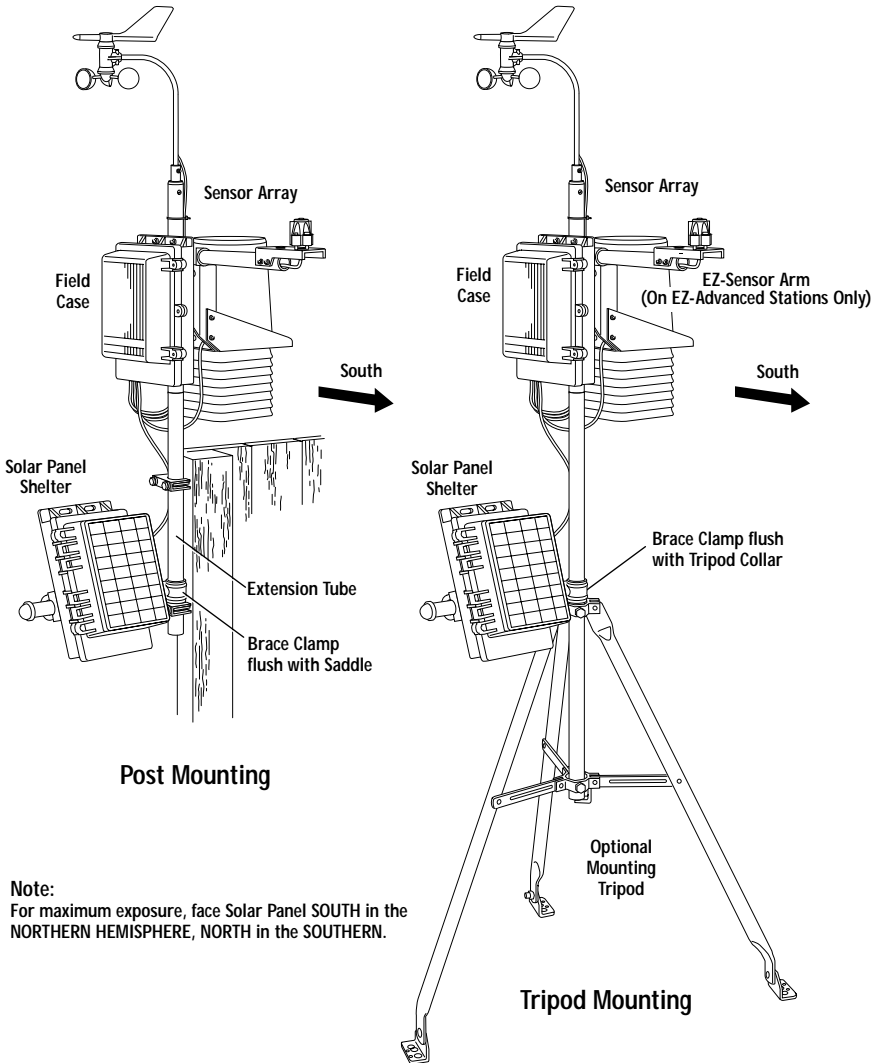

Note: To further open one end of the bolted brace clamp, squeeze the other end closed.

-
4. Attach the brace clamp loosely to the extension tube (or tripod) and insert the arm. Assemble the brace clamp and loosely fasten it to the extension tube. Then, while gripping the extension tube/tripod end of the brace clamp with one hand, slide the arm in as shown below with the other. Tighten.

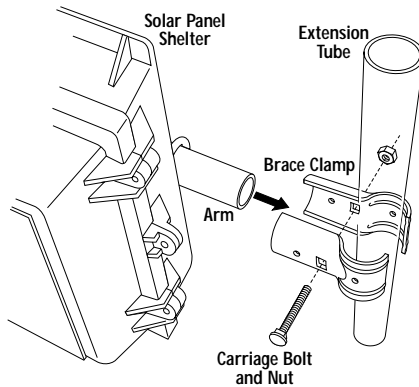

Note: The kit can be positioned to face in any direction depending on which end of the arm you insert into the brace clamp.

5. Position the solar panel shelter to maximize solar exposure. The optimum tilt angle for the panel (measured from the horizontal) is determined by the site latitude:

<u>SITE LATITUDE</u>	<u>RECOMMENDED TILT ANGLE</u>
0° to 4°	10°
5° to 20°	latitude + 5°
21° to 45°	latitude + 10°
46° to 65°	latitude + 15°
65° to 75°	80°

Using a protractor, adjust the tilt angle of the panel until the angle the panel makes with the horizontal matches the recommended tilt angle.

6. Tighten the brace clamp using a wrench.
7. Re-tighten the screws that hold the extension tube to the post.
8. Fit the end cap onto the exposed end of the power kit arm.

CONNECTING THE CABLES

This manual assumes that the console will be mounted in the EZ-Mount field case on the sensor array. If your preferred installation requires the console to be mounted elsewhere, please refer to your station owner's manual for tips on positioning and mounting your console.

1. Open the EZ-Mount station field case door using the flat head screwdriver.
2. Remove 9-volt backup battery from console, if installed.

Do *not* use the backup battery in conjunction with the solar power kit; the station will drain the backup substantially before it taps the solar power.

3. Mount the console on the inside of the field case door (i.e., shelter cover) as shown below.

If you prefer to mount your console elsewhere, see your owner's or system installation manual for instructions and considerations.

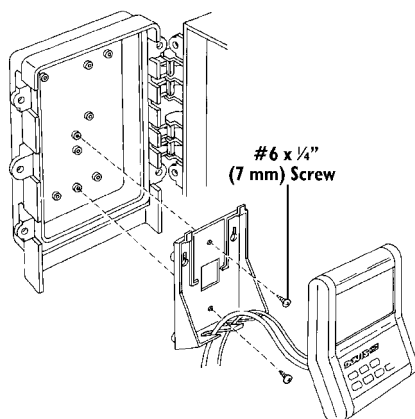

4. If you have an EZ-Mount Advanced Station, remove the SIM (Sensor Interface Module) cover by pressing down on the two tabs on the top plane of the cover.

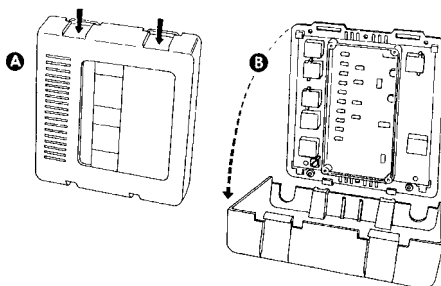

5. Connect the power cord (as shown below).

Run the power cord from the solar kit up through one of the shelter openings at the bottom of the field case. Remove the protective vinyl cap from the power cord plug and then plug it into the console's POWER slot.

The console should beep twice within 10 seconds if the console is working properly. If you have the optional WeatherLink installed, the console should beep three times within 20 seconds.

6. Replace the long 8-conductor cable (for connecting the junction box, SIM, or ICAM to the console) with the 18" (46 cm) cable provided (as shown below).

If you have an industrial installation, this 18" (46 cm) cable replaces both the ICAM *and* the cables leading to and from the ICAM. In order to plug the short 8-conductor cable into the SIM, it may be necessary to unscrew the right-hand ground wire and cut the cable tie holding it in place. If so, remember to screw the ground wire back in and secure it with a cable tie.

EZ-MOUNT WEATHER STATION

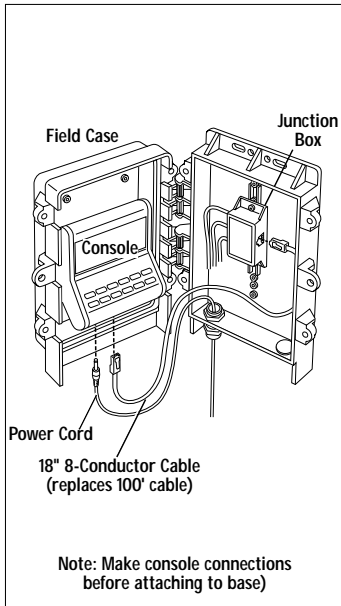

EZ-MOUNT ADVANCED WEATHER STATION

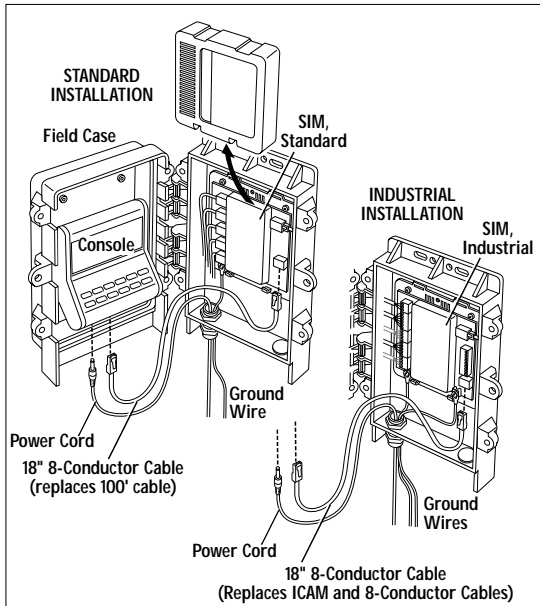

7. Check all of the readings on your display to be sure they appear correctly (i.e., not dashed out).

Consult your owner's manual for instructions on displaying the various readings. Spin the wind cups, move the wind vane, and tip the rain bucket to verify wind speed and direction and rainfall readings. If the console is receiving power but is having problems reading the sensors, please refer to your owner's manual.

8. If everything is working properly, close the station field case door and tighten screws.

-
9. To avoid wind damage, stuff any extraneous cable length back into the field case and use the two cable ties provided to strap any exposed cables to the extension tube (or tripod).

You have completed the installation.

UNDERSTANDING THE SOLAR POWER KIT

Though the EZ installation philosophy allows you to fully install your solar power kit without ever opening its shelter, you may be interested to know something of how the kit operates. Aside from the installation hardware, the kit consists of three key elements—solar panel, battery, and regulator circuit:

◆ Solar Panel

Converts solar energy to electrical energy. The unit provided is rated at 2.5 Watts. It provides about 300 mA of current in bright sunshine (1000 W/m²). In 2 hours it will provide enough power to operate an Advanced Station for more than 24 hours, or a Monitor or Wizard for 48.

Note: *Note: You can clean the solar panel with a water spray, or with a soft cloth and soapy water followed by a clean water rinse.*

◆ Battery

The kit is designed to use the 12 Amp-Hour battery provided, but any 6-volt rechargeable battery may be used. The 12-Amp-Hour battery, when fully charged, can supply power to operate an Advanced Station for 24 days without recharging, assuming an average temperature of 68°F (20°C). It will run for about 21 days at 32°F (0°C) and about 15 days at -4°F (-20°C). Monitor and Wizard stations, under the same conditions, can operate for twice as long.

CAUTION: *The battery is sealed, but it should be assumed that it (and any other rechargeable battery) is capable of generating flammable gas. The battery should be located in a vented space, if possible. No spark, flame, or lighted cigarette should be allowed in the vicinity.*

◆ Regulator Circuit

In order to increase the efficiency and life of the battery, the circuit limits the voltage to which the battery is charged, and it adjusts this voltage according to the temperature at the rate of negative 7.5 mV per °C. This ensures that the battery is fully charged for the conditions, but never over-charged.

TROUBLESHOOTING

While the EZ-Mount weather station is designed to provide years of trouble-free operation, occasional problems may arise. If you experience a problem, please check the troubleshooting tips below before calling technical support.

- ◆ **Console locks up during power up or a power surge**
Insufficient power during power up or a power surge may cause the console to lock up. If this occurs, remove all power by disconnecting the solar power cord. Wait for 1 minute with all of the power removed. Then re-connect the solar power cord and listen for 2 beeps within 10 seconds (or, with the optional WeatherLink, 3 beeps within 20 seconds). Once you receive the final beep, put the console back into service. If the console fails to power up, the solar kit battery may be low—see tips below.
- ◆ **Solar panel fails to power station and battery is over 5 years old**
As the battery ages, it will lose capacity and may completely discharge. If this is the case, simply replace the battery. (Do not incinerate the used battery; it may burst. Arrange for proper recycling in your locality.)
- ◆ **Solar panel fails to power station and battery is less than 5 years old**
If the solar kit fails to power the station, try the following:
Make sure the panel is not being shaded from the sun.
Open the solar panel shelter and check that the wire connections are secure and that battery is free from corrosion and excessive deposits on the terminal.
Clean the solar panel using a water spray, or a soft cloth and soapy water followed by a clean water rinse.
Check the battery's voltage with a voltmeter; the battery must have at least 5.5V to power the station. (More than 6V indicates an adequately-charged battery.) Try exposing the kit (with console unplugged) to ample sunlight for a week, or use a charger designed to recharge a 6V gel cell battery.

If, after checking this troubleshooting guide, you are unable to solve the problem, please call our technical support team at (510) 732-7814 for assistance (M-F, 7 am–5:30 pm PST). Please do not return your unit for repair without prior authorization.

Product Number: 7707

Davis Instruments Part Number: 7395-303

EZ-Solar Power Kit For EZ-Mount Weather Stations

Rev. B Manual (7/7/99) Controlled online: Weather Manuals/Accessories/EZ-Solar Power Kit

This product complies with the essential protection requirements of the EC EMC Directive 89/336/EC.

© Davis Instruments Corp. 1998. All rights reserved.

Weather Monitor II, Weather Wizard III, Health EnviroMonitor, Energy EnviroMonitor, GroWeather and WeatherLink are registered trademarks of Davis Instruments Corp.

DAVIS 
Davis Instruments

3465 Diablo Avenue, Hayward, CA 94545-2778

510-732-9229 • Fax: 510-732-9188

E-mail: info@davisnet.com • www.davisnet.com