

# Standard Anemometer

## Installation Manual

The anemometer measures and displays wind-related conditions such as wind speed, wind direction, wind run, wind chill, and the temperature-humidity-sun-wind index.

### Components

The anemometer includes the components listed below. Be sure you have all listed components before continuing. Assess your installation and make sure you have all necessary parts, tools, and materials pictured below before you begin.

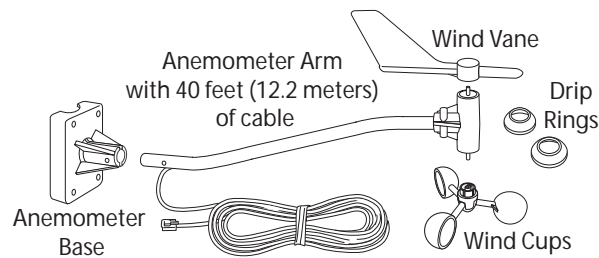

### Hardware

The hardware kit contains the items most commonly needed for the installation of the anemometer. Which items you use from the kit depend on where you install your unit. You may need to adapt or purchase additional hardware to fit your individual requirements. :

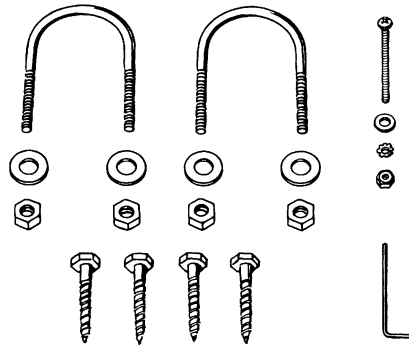

### Tools and Materials Needed

You will need the following tools and materials to install your anemometer:

- Cable Clips or Weather-Resistant Cable Ties

Note: Make sure the clips or ties you use to secure the anemometer cable have screw holes or other means for mounting the cable. Do not use metal staples to secure the cables.

- Stainless Steel Hose Clamps
- Small Screwdrivers
- Adjustable Wrench
- Hand-Held Compass or Local Area Map

## Testing the Anemometer

Before beginning your installation, follow the instructions below to test the anemometer wind speed and wind direction functions.

1. Connect the anemometer cable to the appropriate connector on your junction box.
2. Push the wind cups onto the smaller of the two stainless steel shafts at the end of the arm.
3. Spin the wind cups *gently*. You haven't secured them yet, and if you spin them too hard you may knock them off.
4. Check the display on your weather station to make sure you are getting a wind speed reading.
5. Grab the larger of the two stainless steel shafts at the end of the arm with your fingers and twist the shaft about 1/2 turn.
6. Check the display to make sure the wind direction reading on your display changes.

---

Note: The wind direction readings will not change as rapidly as you turn the shaft. The station uses a low pass filter to smooth out the constant small shifts in wind direction and keep the direction display from jumping about in gusty winds.

---

7. Disconnect the cables when you are finished testing the anemometer.

## Assembling the Anemometer

Attach the drip rings and the wind cups to the anemometer and check the mounting base orientation before you install it. The wind vane is attached after the anemometer has been installed.

### Attaching the Drip Rings

The anemometer drip rings provide protection against icing of the wind vane and wind cups. Follow the instructions below to attach the two drip rings.

1. Place one of the drip rings on a flat surface with the small hole facing up.
2. Securely press the wind vane on top of the drip ring. You may want to start with the vane tilted slightly.
3. Make sure the ring fits securely between the two ridges on the vane with the lower edge parallel to the bottom of the wind vane.
4. Install the small end of the other drip ring on the wind cup end of the anemometer control head as shown below.

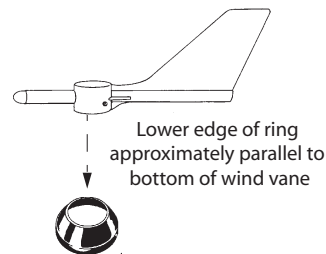

---

Note: The wind cup end of the control head has the smaller of the two stainless steel shafts.

---

5. Gently push up the drip ring until it reaches the groove on the control head.
-

6. Align the lower edge of drip ring with the lower edge of the control head.

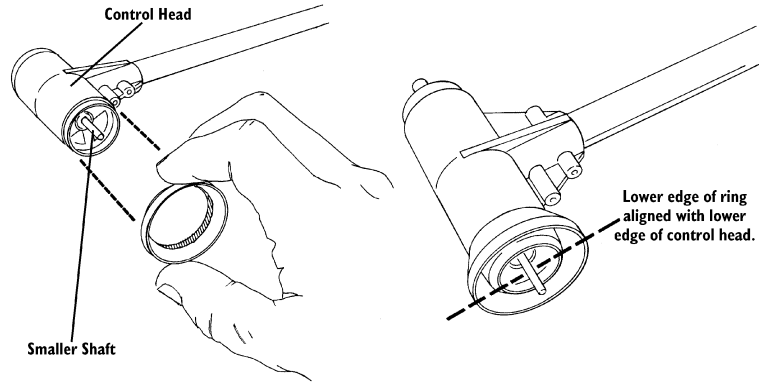

*Installing the drip ring onto the anemometer control head*

### Attaching the Wind Cups

Before installing the anemometer, attach the wind cups. Wait until you have installed the anemometer before you attach the wind vane.

1. Push the wind cups onto the smaller of the two stainless steel shafts .

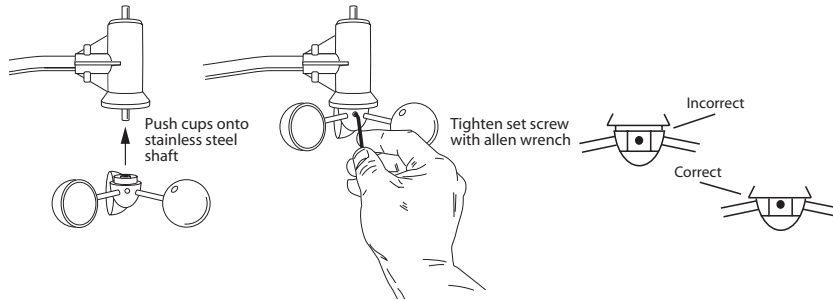

*Attaching wind cups to the anemometer*

2. Slide the wind cups as far up the shaft as possible.
3. Use the allen wrench provided to tighten the set screw on the side of the wind cups.
4. Spin the wind cups. If they do not spin freely, loosen the set screw, lower the cups slightly, then retighten the set screw.
5. Repeat Step 4 until the wind cups spin freely.

### Checking the Anemometer Base Orientation

You will need to know which way to orient the base before installing it.

1. Insert the anemometer arm into the base
2. Attempt to push the #4-40 x 1 1/4" pan head screw through the holes in the arm and the base as described in "Attaching the Wind Vane" on page 6.

3. If the screw does not slide easily through the holes, rotate the base 180° to line up the opposite holes, then try again.
4. Note the correct base orientation for use when you install the base later in the installation process.

## Choosing the Best Anemometer Location

Use the following guidelines to determine the best location for your anemometer.

- Install the anemometer in a location where wind flow is unobstructed by trees and nearby buildings.
- For the most accurate readings, the anemometer should be mounted at least 4 feet (1.2 m) above the roof line.
- You may do this by mounting the anemometer on a television antenna mast, a wooden post, or a metal pipe.
- Make sure the antenna mast or metal pipe is properly grounded. You may want to use Davis' Grounding Kit.
- If you are not certain about how to ground your installation, consult a qualified professional for national and local codes.

---

Note: If you live in an area subject to frequent thunderstorms, installing a lightning rod nearby can reduce the risk of damage.

---

## Installing the Anemometer

Use the following procedures to mount the anemometer:

### Installing on a Sensor Mounting Arm

Consult the Sensor Mounting Arm manual for instructions. You will need to return to this instruction manual after installing onto the Sensor Mounting Arm for instructions on attaching the wind vane (see "Attaching the Wind Vane" on page 6).

### Installing the Base on a Wooden Post or Surface

1. Hold the anemometer base against the wood surface and use a pencil to mark the location of the four holes on the base.
2. Use a drill with a 3/16" (5-mm) drill bit to make pilot holes in these locations.
3. Drive the lag screws through the holes in the anemometer base and into the wood.

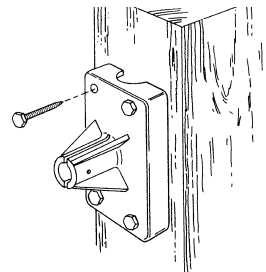

*Attaching base to wooden post*

### Installing on Antenna Mast or Metal Pipe

On an antenna mast or pipe with outside diameter of 7/8" to 1 1/4" (22 to 32 mm):

1. Hold the anemometer base against the pipe and insert the two U-bolts through the back of the base so that the U-bolts wrap around the pipe.
2. Place a 1/4" washer and a 1/4-20 hex nut over each end of the U-bolts and use a wrench to tighten the hex nuts.

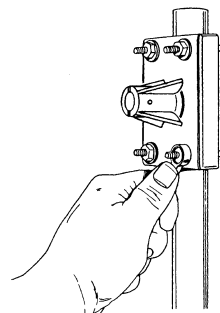

*Attaching base to a pipe using U-bolts*

On a metal pipe with outside diameter greater than 1 1/4 inch (32 mm):

1. Use two stainless steel hose clamps to attach the mounting base to masts or pipes larger than 1 1/4" diameter, large enough to fit around the mast or pipe and the anemometer base.
2. Hold the anemometer base against the pipe and fasten the hose clamps over the anemometer base and around the metal mast or pipe.

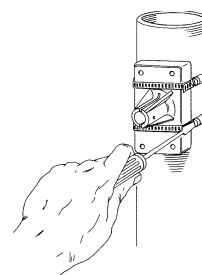

*Attaching base to a pipe using hose clamps*

### Attaching Arm to Base

1. Insert the anemometer arm into the anemometer base.

Guide the anemometer cable through the slot as you insert the arm.

2. Insert the pan head screw into one of the holes in the base and slide it through the arm.

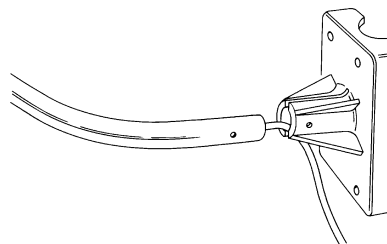

*Inserting arm into base*

3. Secure the pan head screw using the flat washer, lock washer, and hex nut as shown.

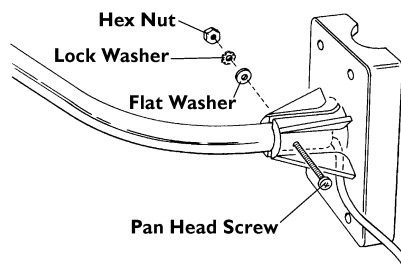

*Attaching the anemometer arm to the base*

---

### Attaching the Wind Vane

To mount the wind vane, look at the console display to orient the vane accurately.

1. Connect the anemometer cable to the SIM/junction box.
2. Press WIND key on console if necessary to display wind direction in degrees.
3. Use a compass or map to determine which direction the arm is pointing.
4. Use the wind direction chart to find the degree reading which corresponds to that direction.
5. Slowly turn the wind direction shaft with your fingers. Stop turning when the weather station display reaches the degree reading obtained in step 4.

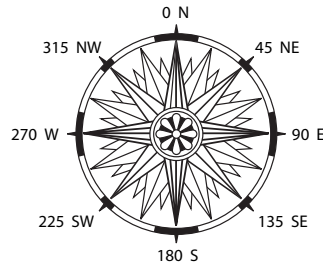

*Wind Direction Chart*

Because of the low pass filter used by the station, the wind direction reading requires approximately 5 seconds to stabilize each time you turn the shaft. You will need to turn the shaft, wait, and turn it again until you eventually “zero in” on the desired wind direction reading.

6. Being careful to keep the stainless steel shaft from turning, place the wind vane on the shaft with the bullet-shaped nose of the vane pointing in the same direction as the arm.

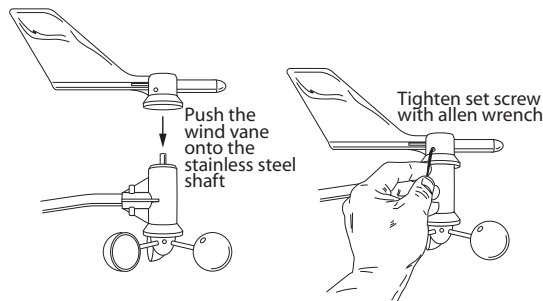

*Installing the wind vane*

7. Slide the wind vane down onto the shaft as far as it will go.
8. Use the allen wrench provided to tighten the set screw on the side of the wind vane.
9. Test your assembly by pointing the wind vane in any direction and (using the compass or map as a guide) making sure the console displays the correct wind direction. Readjust the vane if necessary.
10. Because of the low pass filter used by the station, allow the wind direction reading approximately 5 seconds to stabilize after you turn the vane.

11. Spin the wind cups to make sure you get a wind speed reading. Readjust the cups if necessary.
12. Secure the cable to the metal mast or pipe with electrical tape. Secure the rest of the cable according to the directions below.

### Securing the Cable

To prevent fraying or cutting the anemometer cable where it is exposed to weather, secure it so it doesn't whip about in the wind. Use cable clips or weather resistant cable ties to secure the cable. Place clips or ties approximately every 3 to 5 feet (1 to 1.6 m).

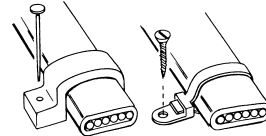

*Securing cable*

Note: Do not use metal staples to secure cables. Metal staples can cut the cables.

## Maintenance

Your anemometer does not require any regular maintenance.

**CAUTION:** DO NOT attempt to lubricate the wind cup shaft and bearings or the wind vane shaft. Natural or synthetic lubricants will inhibit the normal operation of the anemometer.

## Troubleshooting

While your anemometer is designed to provide years of trouble-free operation, occasionally problems may arise. If you are having a problem with your unit, please check the following troubleshooting procedures before sending the unit in for repair. You will be able to solve many of the problems yourself. If, after checking these procedures you are unable to solve the problem, please call Davis Technical Support for further instructions (see "Contacting Davis Instruments Technical Support" on page 8.) Please do *not* return your unit for repair without receiving prior authorization from Davis Technical Support.

### Wind speed reads 0 all the time or intermittently or wind direction reading is dashed out

- Make sure anemometer is plugged into jack marked WIND on junction box.
- Check for broken wire along length of anemometer cable. Carefully check areas where the cable has been secured.
- Try dropping the wind cups approximately 1/16" to 1/8" (1.5 to 3 mm) lower on the mounting shaft. Use the included Allen wrench to loosen and retighten the wind cup assembly.
- If you still do not get a reading, the problem is with the anemometer. Contact Davis Technical Support for return authorization.

---

### Wind speed reading seems too high or too low

- Check installation by spinning wind cups. If the wind cups spin freely and the weather station displays a wind speed, the wind cups are installed correctly. If the wind cups don't spin freely, then try dropping the wind cups approximately 1/16" to 1/8" (1.5 to 3 mm).
- Check calibration number and adjust if necessary.
- Check for any obstructions blocking the wind near the anemometer.

## Contacting Davis Instruments Technical Support

If you have any questions about our products, please call Davis Technical Support. We'll be glad to help. Most questions can be answered while you're on the phone. You can also email us for support, or visit our website. Sorry, we are unable to accept collect calls.

### Phone Support:

(510) 732-7814 – Monday – Friday, 7:00 a.m. – 5:30 p.m. Pacific Time.

(510) 670-0589 – Fax to Technical Support.

### E-mail Support:

[support@davisnet.com](mailto:support@davisnet.com) – E-mail to Technical Support.

[info@davisnet.com](mailto:info@davisnet.com) – E-mail to Davis Instruments.

### Web Support:

[www.davisnet.com](http://www.davisnet.com) – Copies of User Manuals are available on the "Support" page. Watch for FAQs and other updates.

## Specifications

### Wind Direction

Display Resolution: ..... 16 points (22.5°) on compass rose,  
1° in digital display

Accuracy: ..... ± 7°

### Wind Speed

Range: ..... 2 to 175 mph., 4 to 280 kph, 2 to 152  
knots, 0.9 to 78 m/2s

Accuracy: ..... ± 5°

### Standard Anemometer Installation Manual

Rev c (June 24, 2005)

Document Part Number: 7395.032

Product Number: 7911

© Davis Instruments Corp. 2005. All rights reserved.

Information in this document subject to change without notice.



3465 Diablo Avenue, Hayward, CA 94545-2778

510-732-9229 • Fax: 510-732-9188

E-mail: [info@davisnet.com](mailto:info@davisnet.com) • [www.davisnet.com](http://www.davisnet.com)